

Zygmunt Kowalski

Mineral and Energy Economy Research Institute, Polish Academy of Sciences

Agnieszka Makara (amak@chemia.pk.edu.pl)

Katarzyna Fela

Institute of Chemistry and Inorganic Technology, Faculty of Engineering and Chemical Technology, Cracow University of Technology

Agnieszka Generowicz

Institute of Water Supply and Environmental Protection, Faculty of Environmental Engineering, Cracow University of Technology

THE CONCENTRATION OF ANIMAL BLOOD PLASMA USING MEMBRANE METHODS THAT ALLOW ITS RECYCLING AND REUSE

ZATĘŻANIE PLAZMY KRWI ZWIERZĘCEJ METODAMI MEMBRANOWYMI UMOŻLIWIJĄCE JEJ RECYKLIG I WTÓRNE ZUŻYCIE

Abstract

Animal blood plasma contains ~91% water and requires concentration prior to it been dried. Our studies concerned the suitability of membrane technology. The efficiency of the investigated filtration process for membranes was stable over time, and displayed no tendency to clog. The protein level in obtained filtrates ranged from 0.15-0.26%. Increased content of protein in the concentrate is a function of the degree of plasma concentration. For the raw material containing 6.05% proteins, with 2.3 times the concentration, it was 13.84% and with 3 times the concentration, it was 18.24%. The filtration efficiency increases with the temperature of the process but decreases with increased levels of concentration. For both of the investigated membranes the permeability was similar; however, the 0.07 μm membrane had higher filtration efficiency by an average of 30%.

Keywords: blood plasma, membrane techniques, ultrafiltration, concentration

Streszczenie

Plazma krwi zwierzęcej zawiera ok. 91% wody, dlatego wymaga zateżenia przed właściwym suszeniem. Przedstawione wyniki badań wykazały przydatność technik membranowych. Zawartość białka we wszystkich otrzymanych filtratach wynosiła od 0,15 do 0,26%, niezależnie od jego stężenia w plazmie. Stężenie białka w koncentracie wzrasta wraz ze stopniem zateżenia. Dla surowca zawierającego 6,05% białka, przy 2,3-krotnym zateżeniu było równe 13,84%, zaś 3-krotnym 18,24%. Wydajność procesu filtracji membranowej jest stabilna w czasie. Membrany nie wykazują tendencji do zatkania się. Wydajność filtracji wzrasta z temperaturą i maleje wraz ze wzrostem stopnia zateżenia. Dla obu użytych membran przepuszczalność osocza jest porównywalna, jednak membrana 0,07 μm ze względu na wyższą skuteczność filtracji (30%) jest preferowana do stosowania w skali przemysłowej.

Słowa kluczowe: plazma krwi, techniki membranowe, ultrafiltracja, wstępna obróbka plazmy

1. Introduction

One of the by-products of animal slaughter is blood and due to its composition and properties, it is interesting material which can be processed into food ingredients or feed [1-3]. For this purpose, only blood which has been subjected to veterinary testing to ensure that it is free from viral diseases can be used; this applies whether the blood is bovine or porcine. The ban on the use of meat and bone meal, which was introduced after the European countries due to BSE over 10 years ago, does not apply to feed from the processing of blood, such as blood meal, haemoglobin feed or dried blood plasma. Feed containing blood meal is not only a rich source of protein, but also promoter's resistance suitable in the feeding of monogastric animals [4-6].

From a physicochemical point of view, blood is slurry consisting essentially of the cellular components and serum of plasma, wherein the cells are suspended. The liquid part of blood is plasma; it is comprised of around 91% water, 8% organic compounds and 1% inorganic compounds which are responsible for the maintenance of acidic-alkaline balance of the animal's body. The organic compounds are mainly proteins and lipoproteins, fatty acids, cholesterol, triglycerides, hormones, glucose, vitamins, the products of protein metabolism (urea, amino acids) and haem (bilirubin and urobilinogen). Inorganic compounds include carbon dioxide and the salts of sodium, calcium, magnesium, potassium and anions containing chlorine, carbon and phosphorus [7, 8].

Blood is a product commonly obtained in an animal slaughterhouse which shows high impermanence, ease undergo haemolysis and provides an excellent base for the development of pathogenic bacteria. Therefore it requires rapid treatment or disposal. One of the main methods of processing is the separation of the blood into plasma and haemoglobin [9]. Due to differences in the specific gravities of blood cells and plasma, it is possible to perform their separation using centrifugation. Plasma obtained through centrifugation typically contains approx. 8-9% of dry mass. Unfortunately, the opportunity to use the thus obtained raw material in liquid form is minimal due to the rapidly progressing biochemical processes which result in the loss of nutritional properties of any food product that it is used to produce. Therefore, the plasma is further processed in order to obtain a product in which both the stability and the properties are improved. There are two main ways of processing, the first is drying which produces powdered plasma, and the second is freezing which, depending on the specific method used, produces either plasma blocks or flakes. Both dried plasma and frozen plasma are products that can be stored for use over a much longer time than liquid plasma [10, 11].

Dried blood plasma has high protein content, depending on the technological drying process, its content ranges from 70 to 80%. Within the major protein fraction of the blood plasma, the following components can be identified: albumin (approx. 50%); α -globulins (15%); β -globulins (15%); γ -globulin, which includes the most valuable immune globulin (15%) – this naturally stimulates the functioning of the immune system of animals. The obtained product, however, had lower concentration of sulphur amino acids, which deficiency should be completed during the preparation of feeds. This product is also rich in minerals, and the macro- and micronutrients which are necessary for the proper functioning of animal organisms [12, 13].

In the production processes of dried blood plasma, water plays important role. The higher the amount of water in the centrifuged plasma, the greater is the costs which must be incurred for its further processing. Thus, an initial plasma concentration is used to minimise the expense and time of drying or freezing. At present, there are two leading techniques used for the concentration of plasma – membrane processes and concentration by evaporation [8, 10, 11].

The paper presents research results on the suitability of membrane technology for the concentration of animal blood plasma and the production of plasma solutions with higher contents of protein and dry matter. The obtained results showed that this method can be successfully used for this purpose.

2. Experimental procedure

Membrane processes [8, 14, 15] exploit the properties of the materials which the membrane is made of to retain certain components of the mixtures during the separation process. The driving force of mass transfer across the membrane is the potential difference which occurs on each side of the membrane. It may be caused by the concentration difference, temperature or pressure. Membrane techniques which can be of use in the concentration of plasma include ultrafiltration, nanofiltration and reverse osmosis. The parameter differs these techniques is selectivity. Diagrams showing the differences between the different techniques of the treatment of animal plasma are presented below in Figure 1.

Concentration of the plasma solution using evaporators is a technique utilising differences in the boiling points of the two liquid components of the solution which causes the solvent (in the case of the plasma, it is water) to be removed through the process of evaporation during heating of the concentrate (protein solution). Evaporators used in the process of plasma concentration usually operate in a vacuum in order to give the plasma a boiling point of 36°C – this keeps the protein denaturation in the concentrated solution. By using the evaporating apparatus it is possible to obtain concentrated plasma with a dry mass content of 25-27%. Two types of evaporation devices are mainly used for the concentration this type of product. The first is the Centritherm type of evaporator, which consists of a number of heated rotating cones, these evaporate the dosed liquid within. In this solution, the plasma goes to the evaporator through a pipe system and is distributed over the heated surface of the cone through nozzles (one for each cone). The centrifugal force spreads the product over the entire heated surface in a very thin layer (approx. 0.1 mm). These cones rotate at a speed of 600 rpm and the plasma is transferred from the centre to the edge in about one second. The concentrated product is collected on the outer edge of the cone and leaves the apparatus. The resulting steam is transferred to the centre of the cone and then through a system of outlet tubes, it is removed to an external condenser. The heated steam is passed to the interior of each of the cones by a plunge pin. The advantage of using Centritherm evaporators is a very short time of contact with the hot surface of the apparatus – this prevents excessive denaturation of the protein [11].

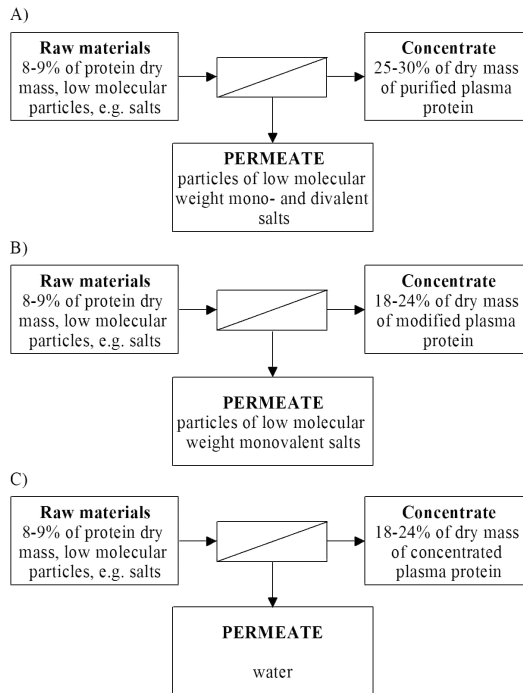

Fig. 1. Flow charts of the plasma concentration processes using A) ultrafiltration, B) nanofiltration, and C) reverse osmosis

The second type of devices used in the evaporative concentration of plasma are film evaporators in which liquid and vapour fall through a system of parallel, vertical tubes surrounded by a heated jacket. Supplied to the plasma apparatus is preheated and next followed by distribution system located at the head of the evaporator, flows down the inner periphery of the tube in the form of a thin film from where water vapour are evaporated. After leaving the calandria, concentrate is collected in the bottom of the evaporator and fumes are drawn into the side chamber to be ejected. Thin-film evaporators can be operated with a very small temperature difference between the heating medium and the boiling liquid, they also have a very short contact time, usually only a few seconds for a single run. This results in thin-film evaporators that are particularly useful for temperature-sensitive products, which includes animal plasma [11, 14].

3. Results and discussion

Below, the effects of using ultrafiltration on two pilot units, Alfa Laval and Intermaasz, for the concentration of porcine blood plasma are compared. The conditions under which these processes are realised are discussed as is the efficiency of the processes based on the results of testing the obtained products. The first test was performed on membranes from Alfa Laval. Figure 2 shows a flow diagram of the Alfa Laval experimental unit.

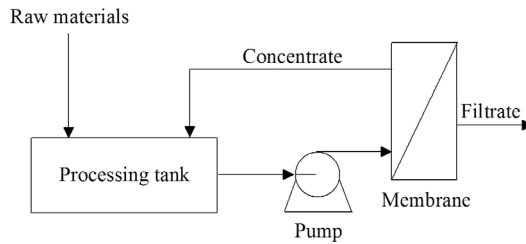

Fig. 2. Flow diagram of the Alfa Laval experimental unit

In the study, a spiral type membrane DSS-GR70PE-3838/80 with an area of 7 m² was used. The processing tank was filled with a quantity of porcine plasma prior to commencement of the tests. The process parameters were determined after the pump was switched on and the pressure differential was set. The process was conducted at differential pressures of 1 and 1.2 bars to obtain the assumed values, as measured by the change in volume of the solution introduced to the ultrafiltration unit.

The raw materials used and products obtained during the tests were sampled on the input and output, respectively and analysed in order to evaluate the content of protein and dry matter within the sample – these results are shown in Table 1. Figures 3 and 4 present dependences of the growth in protein content and dry weight, and the degree of concentration in the plasma solution.

Table 1. The results of analyses of the concentration of plasma solution with the use of membranes from Alfa Laval

No.	Differential pressure [bar]	Concentration degree	Raw material		Product	
			Protein [%]	Dry mass [%]	Protein [%]	Dry mass [%]
1	1.0	1.35	7.43	9.46	10.05	12.45
2		1.43	6.79	9.55	10.58	14.02
3		1.47	5.77	8.02	10.70	13.73
4		1.72	6.70	8.89	12.02	14.79
5	1.2	1.67	7.40	9.86	11.44	13.98
6		1.89	6.36	8.98	11.91	15.33
7		2.50	6.67	9.29	12.52	16.20
8		2.86	6.89	9.47	14.39	17.87

Ultrafiltration tests were then carried out on membranes from TAMI Industries using an experimental unit from the Intermasz Company, the schematic diagram of which is shown in Figure 5. In the study, two 23-channel ceramic microfiltration membranes of TAMI Industries were used, each with a filter area of 0.35 m² and with separation limits of 300 kD and 0.07 microns. The raw material for the filtration was periodically taken from the plasma storage tank and pumped to the plasma process tank of the experimental unit. The filtrate was continuously discharged outside the system. Concentrate comprising substantially all the proteins, remained in the filtration system.

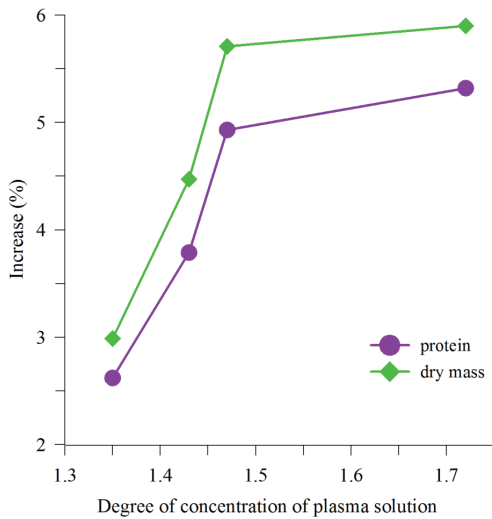

Fig. 3. Dependence of increase of the protein and dry matter in the plasma concentrate and the degree of concentration of the raw material at a pressure difference of 1 bar

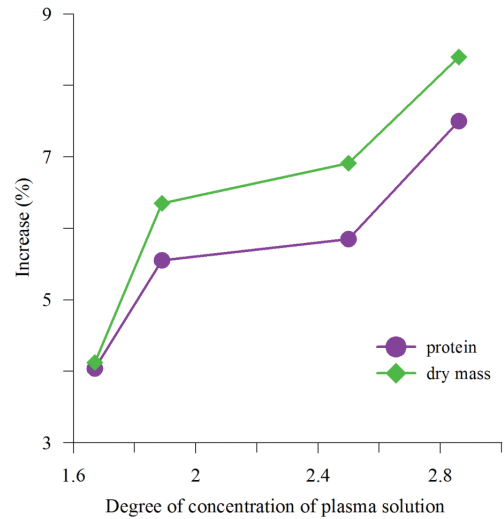

Fig. 4. Dependence of increase of the protein and dry matter in the plasma concentrate and the degree of concentration of the raw material at a pressure difference of 1.2 bar

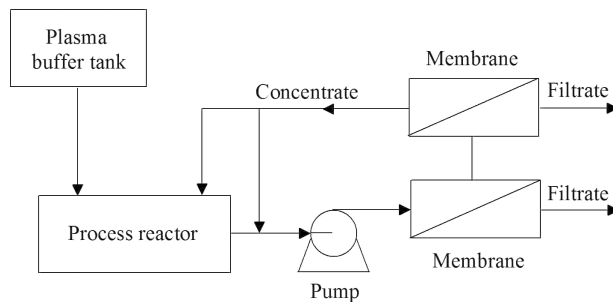

Fig. 5. Flow diagram of the IntermaSz experimental unit for the concentration of animal blood plasma using the ultrafiltration method

Two tests were conducted. Filtrate and concentrate samples collected during the testing of raw materials were analysed to determine the amount of protein and dry matter in the filtrate and concentrate. Test 1 was carried out for duration of 3 hours 45 min, in the temperature range 22-40°C. The ultrafiltration of 70 dm³ of plasma produced 20 dm³ of concentrate and 50 dm³ of filtrate. The output had approx. 3.5 times higher density than the input raw material. In the period from 0 to 1 hour 25 min, the efficiency of the process for the 300 kD UF membrane increased from 16 to 31 dm³/h m² and for the 0.07 µm membrane, the increase was from 20 to 36 dm³/h m². These resulted from the increase in temperature and followed the systematic increase in the level to 1.35 times the concentration. Fixed transmembrane pressure equal to 2 bars and a temperature range of 35-40°C was used later in the study. A systematic decrease in performance for the 300 kD membrane of 31 dm³/h m² at 1.35-fold concentration to a level of approx. 4 dm³/h m² to 3.4-fold concentration was observed. There

was also a steady decrease in performance for the 0.07 μm membrane with 36 $\text{dm}^3/\text{h m}^2$ at 1.35-fold concentration of up to approx. 7 $\text{dm}^3/\text{h m}^2$ to 3.4-fold concentration.

Test 2 was carried out for duration of 6 hours 10 min. 60 dm^3 of plasma was concentrated to obtain 20 dm^3 of concentrate and 40 dm^3 of filtrate. The process of plasma concentration was interrupted several times due to adding recycled filtrate into process tank and work on a few selected levels of concentration. Finally, a ~ 3 -fold higher density than the input raw material was obtained.

The results of analyses of the samples of filtrate and concentrate are summarised in Table 2.

Table 2. Results of plasma solution concentration on membranes of TAMI Industries

Object of analysis	Dry mass [%]	Protein [%]
Test 1		
Plasma before concentration	8.99	6.10
Concentrate (3.5-fold concentration)	24.62	19.94
Test 2		
Plasma for filtration	8.99	6.10
Filtrate – membrane 0.07 μm after 20 minutes	2.79	0.25
Filtrate – membrane 300 kD after 20 minutes	2.75	0.15
Filtrate – membrane 0.07 μm (2.3-fold concentration)	2.93	0.26
Filtrate – membrane 300 kD (2.3-fold concentration)	3.08	0.23
Concentrate (2.3-fold concentration)	17.72	13.84
Filtrate – membrane 0.07 μm (3-fold concentration)	2.95	0.23
Filtrate – membrane 300 kD (3-fold concentration)	3.19	0.19
Concentrate (3-fold concentration)	22.65	18.24

In the described test, the process was performed at four selected concentration levels – 1.5-fold, 2-fold, 2.25-fold and 3-fold. After obtaining each of these concentration levels, the concentration process was stopped and the filtrate was recycled to the process reactor and the filtrate was once again concentrated. The dependence of filtration efficiency for the two applied types of TAMI Industries membranes and the degree of plasma concentration are presented in Figure 6.

After reaching the level of 1.5-fold concentration, the filtration efficiency for the 300 kD membrane was 27 $\text{dm}^3/\text{h m}^2$ at 32°C. The increase in temperature to 40°C after 2 h resulted in an increase in the filtration efficiency to 33 $\text{dm}^3/\text{h m}^2$. The process was conducted for a further 55 min while maintaining the previously achieved level of filtration efficiency. After reaching 1.5-fold concentration, filtration efficiency for the 0.07 micron membrane was 37 $\text{dm}^3/\text{h m}^2$ at 32°C. The increase in temperature after 2 h to 40°C resulted in an increase of filtration efficiency of 45 $\text{dm}^3/\text{h m}^2$. The process was conducted for a further 55 min while maintaining the previously achieved level of efficiency.

Filtration efficiency of the 300 kD membrane at 2-fold concentration remained at a stable level of 19 $\text{dm}^3/\text{h m}^2$, and at the 2.25-fold concentration, it decreased to 16 $\text{dm}^3/\text{h m}^2$. For the target 3-fold concentration, the efficiency was 8.5 $\text{dm}^3/\text{h m}^2$. Filtration efficiency of the



0.07 micron membrane at 2-fold concentration remained at a stable level of approx. 27 dm³/h m², and at the 2.25-fold concentration, it decreased to approx. 24 dm³/h m². For the target 3-fold concentration, the efficiency amounted to approx. 12 dm³/h m².

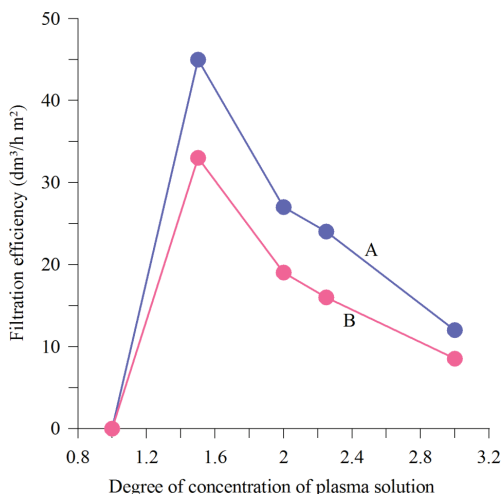

Fig. 6. Dependence of filtration efficiency of TAMI Industries membranes and degree of plasma concentration: A – membrane 0.07 μm; B – membrane 300 kD

4. Conclusions

Studies on animal blood plasma ultrafiltration with an Alfa Laval membrane were treated as preliminary tests in order to assess the suitability of membrane technology for the plasma concentration to produce plasma solutions with higher contents of protein and dry matter. The results obtained showed that this method can be successfully used for this purpose.

Tests carried out on the Intermasz unit were realized for a more detailed characterization of the concentration process especially to determine the influence of selected process parameters on the concentration efficiency. The results showed that the tested membrane functions meet the expected results in terms of protein retention on the concentrate side. The protein level in all obtained filtrates ranged from 0.15-0.26%, regardless of the plasma concentration in the system. Increase in the level of protein in the concentrate is a function of the plasma concentration in the system. Assuming that the content of protein in the raw material amounted to approx. 6.05%, compared protein level in concentrate was higher by 2.3 times (13.84% protein) and 3 times (18.24% protein). These allow to state that close 100% of processed proteins were concentrated.

Comparisons between the levels of dry mass in the filtrates obtained at different levels of concentration enable us to state that the tested membranes are characterised by similar levels of permeability to other components of the plasma (from a slightly higher permeability of the 0.07 μm membrane).

The efficiency of the filtration process for both membranes was stable over time, the membrane showed no tendency to clog. The filtration efficiency was dependent upon the process temperature (positive correlation) and the degree of concentration (negative correlation). Filtration efficiency of the 0.07 μm membrane used in Test 1 was 20-25% higher than that of the 300 kD membrane, while for the 0.07 micron membrane in Test 2, the filtration efficiency was higher at approx. 40%. For both membranes, the permeability of the plasma was similar; however, the 0.07 μm membrane had an average 30% higher filtration efficiency than the 300 kD membrane and is more suitable for use in any industrial plant.

The obtained concentrate of blood plasma can be recycled (off-process recycling) and re-used as a valuable component in the production of foodstuffs.

References

- [1] Bah C.S.F., Bekhit A.E.-D.A., Carne A., McConnell M.A., *Slaughterhouse Blood: An Emerging Source of Bioactive Compounds*, Comprehensive Reviews in Food Science and Food Safety, vol. 12(3), 2013, 314-331.
- [2] Lynch S.A., Mullen A.M., O'Neill E.E., García C.Á., *Harnessing the Potential of Blood Proteins as Functional Ingredients: A Review of the State of the Art in Blood Processing*, Comprehensive Reviews in Food Science and Food Safety, vol. 16(2), 2017, 330-344.
- [3] Silva V.D.M., Silvestre M.P.C., *Functional properties of bovine blood plasma intended for use as a functional ingredient in human food*, Lebensmittel-Wissenschaft & Technologie, vol. 36(7), 2003, 709-718.
- [4] King R.H., Campbell R.G., *Blood meal as a source of protein for grower/finisher pigs*, Australian Society of Animal Production, vol. 12, 1978, 149.
- [5] Lafarga T., Wilm M., Wynne K., Hayes M., *Bioactive hydrolysates from bovine blood globulins: Generation, characterization, and in silico prediction of toxicity and allergenicity*, Journal of Functional Foods, vol. 24, 2016, 142-155.
- [6] Przybylski R., Firdaous L., Châtaigné G., Dhulster P., Nedjar N., *Production of an antimicrobial peptide derived from slaughterhouse by-product and its potential application on meat as preservative*, Food Chemistry, vol. 211(15), 2016, 306-313.
- [7] Toldra M., Elias A., Pares D., Saguer E., Carretero C., *Functional properties of a spray-dried porcine red blood cell fraction treated by high hydrostatic pressure*, Food Chemistry, vol. 88(3), 2004, 461-468.
- [8] Konopka M., Kowalski Z., Fela K., Klamecka A., Cholewa J., *Otrzymywanie plazmy metodą wirowania krwi – charakterystyka procesu*, Czasopismo Techniczne, 1-Ch/2007, 67-74.
- [9] Ockerman H.W., Hansen C.L., *Animal By-Product Processing and Utilization*, CRC Press, Boca Raton, Florida 2000.
- [10] Kowalski Z., Makara A., Banach M., *Krew zwierzęca, metody jej przetwarzania i zastosowanie*, Czasopismo Techniczne, 2-Ch/2011, 87-105.



- [11] Kowalski Z., Makara A., Banach M., *Blood plasma and hemoglobin production process*, Chemik, vol. 65(5), 2011, 466-475.
- [12] Lafarga T., Hayes M., *Bioactive protein hydrolysates in the functional food ingredient industry: Overcoming current challenges*, Food Reviews International, vol. 33(3), 2017, 217-246.
- [13] Bah C.S.F., Bekhit A.E.-D.A., Carne A., McConnell M.A., *Composition and biological activities of slaughterhouse blood from red deer, sheep, pig and cattle*, Journal of the Science of Food and Agriculture, vol. 96(1), 2015, 79-89.
- [14] *Membrany i membranowe techniki rozdziału*, (ed.) A. Narębska, Wydawnictwo Uniwersytetu Mikołaja Kopernika, Toruń 1997.
- [15] Bodzek M., Bohdziewicz J., Konieczny K., *Techniki membranowe w ochronie środowiska*, Wydawnictwo Politechniki Śląskiej, Gliwice 1997.